



RF Components

C-band Passive Equalisers

1250 - 3750 MHz

Model Number:
EQUC5P-457004

- Reciprocal device
- DC/10MHz block
- 2dB positive slope

Available with RF connector options:

- 50 Ω SMA
- 50 Ω N-type

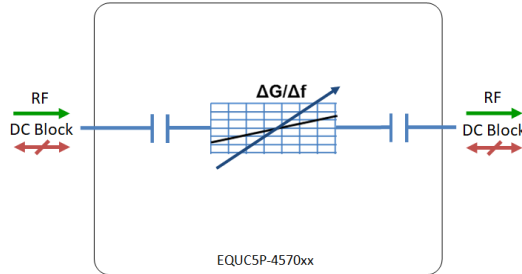

1250-3750 MHz
Operating frequency range



Compact
Housed in rugged compact enclosure



Flexible Mounting
Tapped screw & through hole mounting options



RF Parameters		
EQUC5P-457004-xxxx	S5S5	N5N5
Frequency Range	1250 - 3750 MHz	
RF Connectors	50Ω SMA	50Ω N-Type
Insertion Loss at 3750MHz (dB)	Typ.	2.5
	Max.	3.5
Slope Positive (dB)	2.0 ± 1.0	2.0 ± 1.0
Input Return Loss (dB)	Typ.	12
	Min	10
Output Return Loss (dB)	Typ.	12
	Min	10

Broadcast



Marine Oil & Gas



SNG & VSAT



Satellite Teleport





RF Components

Model Number:
EQUC5P-457004
C-band Passive Equalisers

Technical specifications and operating parameters

Environmental	
Operating Temperature	0°C to +45°C
Storage Temperature	-20°C to +75°C
Location	Indoor use Only
Humidity	Max 85% non-condensing
Altitude	Max 10,000 feet

Max Operating Parameters	
Input RF Power	+ 16 dBm (40 mW)
DC Voltage	35 V on any RF port
DC Current	500 mA

! Operation beyond these limits may cause instantaneous and permanent damage.

Physical Dimensions (mm)

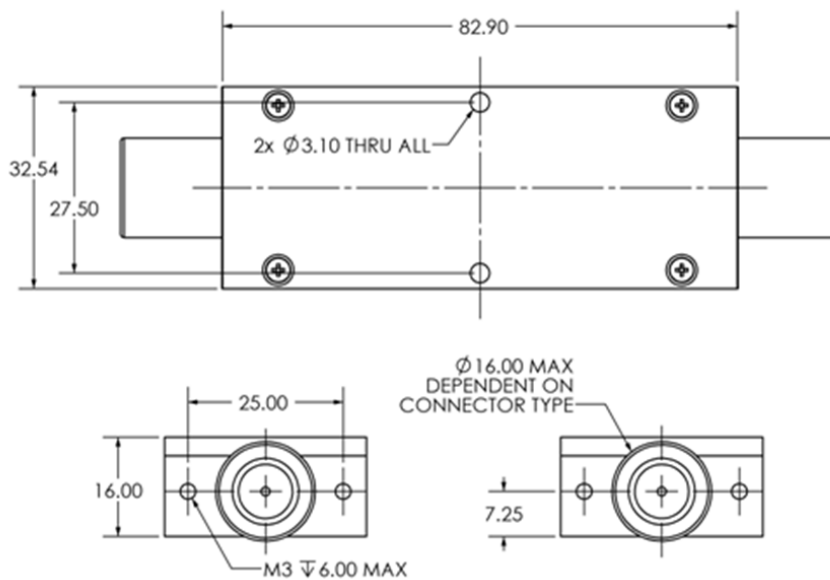

Note: The specification is subject to regular reviews and will be updated from time to time as part of our continuing product development and improved specification accuracy.

ETL SYSTEMS LIMITED
Coldwell Radio Station
Madley
Hereford
England HR2 9NE

TELEPHONE
+44 (0)1981 259020

EMAIL
info@etlsystems.com

FACSIMILE
+44 (0)1981 259021

WEB
www.etlsystems.com

