



A-GABL1-3357 to 3361

RF Engineering & Custom Build

In Line Amplifier



A-GABL1-3357 to 3361 series are a of tubular L-band (850 –2150 MHz) with 10, 15, 20, 25 & 30 dB fixed Gain, DC and 10 MHz block. These amplifiers are in line biased from the input port and require 8 to 24v DC.

This component is available with the following RF connector options: 50Ω SMA, N-type, BNC and 75 Ω BNC or F-type.

Vector diagram

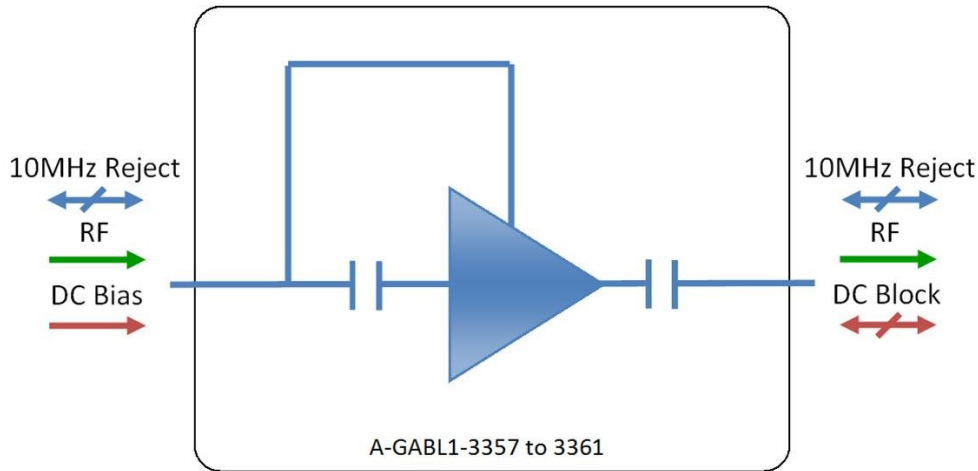

RF Parameters

A-GABL1-3357-xxxx	S5S5	N5N5	B5B5	B7B7	F7F7
Frequency Range	850-2150 MHz	850-2150 MHz	850-2150 MHz	850-2150 MHz	850-2150 MHz
RF Connectors	75Ω BNC	75Ω BNC	75Ω BNC	75Ω BNC	75Ω BNC
Gain	10 ±0.5 dB	10 ±0.5 dB	10 ±0.5 dB	10 ±0.5 dB	10 ±0.5 dB
Flatness	± 0.6 dB	± 0.6 dB	± 0.6 dB	± 0.7 dB	± 1.0 dB
Input Return Loss	22 dB typ	22 dB typ	18 dB typ	12 dB typ	12 dB typ
	14 dB min	14 dB min	12 dB min	8 dB min	8 dB min
Output Return Loss	20 dB typ	20 dB typ	18 dB typ	15 dB typ	15 dB typ
	12 dB min	12 dB min	12 dB min	8 dB min	8 dB min
1 dB GCP*	4 dBm typ	4 dBm typ	4 dBm typ	4 dBm typ	4 dBm typ
	0 dBm min	0 dBm min	0 dBm min	0 dBm min	0 dBm min
IP3	14	14	14	14	14
Noise Figure	16	16	16	16	16

1dB Gain Compression Point (1dB GCP) is in relation to output power.

BROADCAST



MARINE OIL & GAS



SNG & VSAT



SATELLITE TELEPORT





A-GABL1-3357 to 3361

RF Engineering & Custom Build

In Line Amplifier

RF Parameters

A-GABL1-3358-xxxx	S5S5	N5N5	B5B5	B7B7	F7F7
Frequency Range	850-2150 MHz	850-2150 MHz	850-2150 MHz	850-2150 MHz	850-2150 MHz
RF Connectors	75Ω BNC	75Ω BNC	75Ω BNC	75Ω BNC	75Ω BNC
Gain	15 ±0.5 dB	15 ±0.5 dB	15 ±0.5 dB	15 ±0.5 dB	15 ±0.5 dB
Flatness	± 0.6 dB	± 0.6 dB	± 0.6 dB	± 0.7 dB	± 1.0 dB
Input Return Loss	22 dB typ	22 dB typ	18 dB typ	12 dB typ	12 dB typ
	14 dB min	14 dB min	12 dB min	8 dB min	8 dB min
Output Return Loss	20 dB typ	20 dB typ	18 dB typ	15 dB typ	15 dB typ
	12 dB min	12 dB min	12 dB min	8 dB min	8 dB min
1 dB GCP*	8 dBm typ	8 dBm typ	8 dBm typ	8 dBm typ	8 dBm typ
	4 dBm min	4 dBm min	4 dBm min	4 dBm min	4 dBm min
IP3	18	18	18	18	18
Noise Figure	14	14	14	14	14

1dB Gain Compression Point (1dB GCP) is in relation to output power.

RF Parameters

A-GABL1-3359-xxxx	S5S5	N5N5	B5B5	B7B7	F7F7
Frequency Range	850-2150 MHz	850-2150 MHz	850-2150 MHz	850-2150 MHz	850-2150 MHz
RF Connectors	75Ω BNC	75Ω BNC	75Ω BNC	75Ω BNC	75Ω BNC
Gain	20 ±0.5 dB	20 ±0.5 dB	20 ±0.6 dB	20 ±0.75 dB	20 ±0.75 dB
Flatness	± 0.6 dB	± 0.6 dB	± 0.6 dB	± 0.7 dB	± 1.0 dB
Input Return Loss	22 dB typ	22 dB typ	18 dB typ	12 dB typ	12 dB typ
	14 dB min	14 dB min	12 dB min	8 dB min	8 dB min
Output Return Loss	20 dB typ	20 dB typ	18 dB typ	15 dB typ	15 dB typ
	12 dB min	12 dB min	12 dB min	8 dB min	8 dB min
1 dB GCP*	10 dBm typ	10 dBm typ	10 dBm typ	10 dBm typ	10 dBm typ
	6 dBm min	6 dBm min	6 dBm min	6 dBm min	6 dBm min
IP3	20	20	20	20	20
Noise Figure	12	12	12	12	12

1dB Gain Compression Point (1dB GCP) is in relation to output power.

BROADCAST



MARINE OIL & GAS



SNG & VSAT



SATELLITE TELEPORT





A-GABL1-3357 to 3361

RF Engineering & Custom Build

In Line Amplifier

RF Parameters

A-GABL1-3360-xxxx	S5S5	N5N5	B5B5	B7B7	F7F7
Frequency Range	850-2150 MHz	850-2150 MHz	850-2150 MHz	850-2150 MHz	850-2150 MHz
RF Connectors	75Ω BNC	75Ω BNC	75Ω BNC	75Ω BNC	75Ω BNC
Gain	25 ±0.5 dB	25 ±0.5 dB	25 ±0.5 dB	25 ±0.5 dB	25 ±0.5 dB
Flatness	± 0.6 dB	± 0.6 dB	± 0.6 dB	± 0.7 dB	± 1.0 dB
Input Return Loss	22 dB typ	22 dB typ	18 dB typ	12 dB typ	12 dB typ
	14 dB min	14 dB min	12 dB min	8 dB min	8 dB min
Output Return Loss	20 dB typ	20 dB typ	18 dB typ	15 dB typ	15 dB typ
	12 dB min	12 dB min	12 dB min	8 dB min	8 dB min
1 dB GCP*	14 dBm typ	14 dBm typ	14 dBm typ	14 dBm typ	16 dBm typ
	10 dBm min	10 dBm min	10 dBm min	10 dBm min	10 dBm min
IP3	26	26	26	26	26
Noise Figure	10	10	10	10	10

1dB Gain Compression Point (1dB GCP) is in relation to output power.

RF Parameters

A-GABL1-3361-xxxx	S5S5	N5N5	B5B5	B7B7	F7F7
Frequency Range	850-2150 MHz	850-2150 MHz	850-2150 MHz	850-2150 MHz	850-2150 MHz
RF Connectors	75Ω BNC	75Ω BNC	75Ω BNC	75Ω BNC	75Ω BNC
Gain	30 ±0.5 dB	30 ±0.5 dB	30 ±0.6 dB	30 ±0.75 dB	30 ±0.75 dB
Flatness	± 0.6 dB	± 0.6 dB	± 0.6 dB	± 0.7 dB	± 1.0 dB
Input Return Loss	22 dB typ	22 dB typ	18 dB typ	12 dB typ	12 dB typ
	14 dB min	14 dB min	12 dB min	8 dB min	8 dB min
Output Return Loss	20 dB typ	20 dB typ	18 dB typ	15 dB typ	15 dB typ
	12 dB min	12 dB min	12 dB min	8 dB min	8 dB min
1 dB GCP*	16 dBm typ	16 dBm typ	16 dBm typ	16 dBm typ	16 dBm typ
	12 dBm min	12 dBm min	12 dBm min	12 dBm min	12 dBm min
IP3	26	26	26	26	26
Noise Figure	8	8	8	8	8

1dB Gain Compression Point (1dB GCP) is in relation to output power.

BROADCAST



MARINE OIL & GAS



SNG & VSAT



SATELLITE TELEPORT





A-GABL1-3357 to 3361

RF Engineering & Custom Build

In Line Amplifier

Environmental

Operating Temperature	0°C to 45°C
Storage Temperature	-20°C to +75°C
Location	Indoor use Only
Humidity	85% non-condensing
Altitude	10,000 feet

Max Operating Parameters

Input RF Power	+16 dBm (40mW)
DC Voltage	35V on any RF port
DC Current	750mA
DC Consumption	
A-GABL1-3357 & 3358	100mA Max typ 80mA
A-GABL1-3359 to 3361	200mA Max typ 160mA

! Operation beyond these limits may cause instantaneous and permanent damage.

Physical dimensions

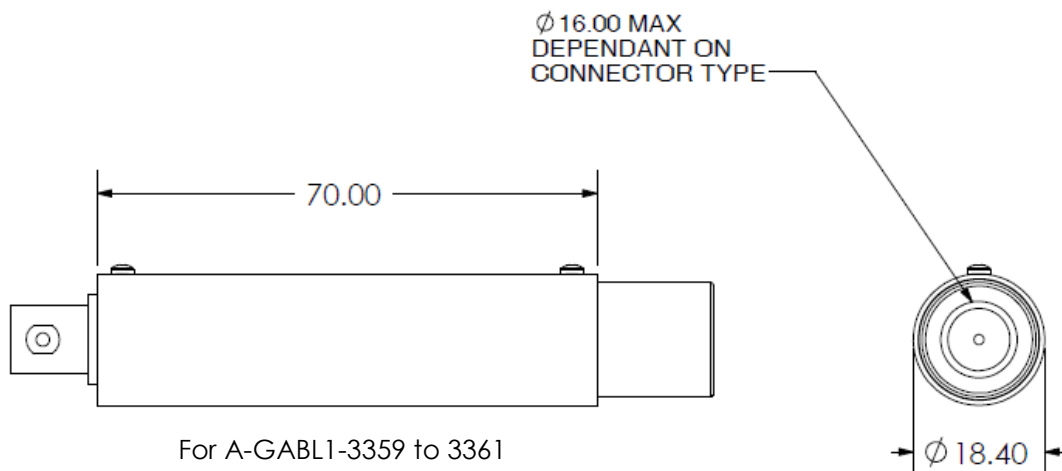
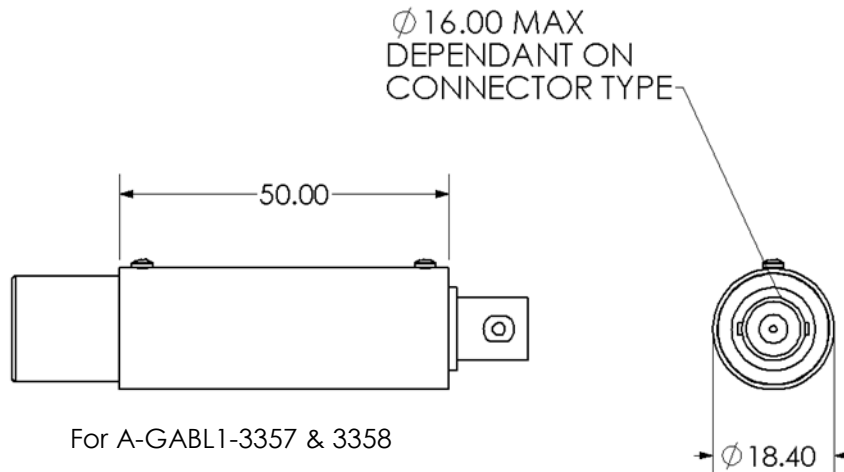

ETL SYSTEMS LIMITED
 Coldwell Radio
 Station
 Madley
 Hereford

England HR2 9NE
 TELEPHONE
 +44 (0)1981 259020

EMAIL
info@etlsystems.com
 FACSIMILE
 +44 (0)1981 259021



V 1.1 E&OE



A-GABL1-3357 to 3361

RF Engineering & Custom Build

In Line Amplifier

Feature set for alternative L-Band Gain Block Amplifiers

Model Number	Bias Option	Frequency vs. Gain	Gain Options (dB)	Other Features
A-GABL1-3331	In-line	Flat	10	DC pass on all ports
A-GABL1-3332	In-line	Flat	15	DC pass on all ports
A-GABL1-3333	In-line	Flat	20	DC pass on all ports
A-GABL1-3334	In-line	Flat	25	DC pass on all ports
A-GABL1-3335	In-line	Flat	30	DC pass on all ports
A-GABL1-3336	In-line	Flat	10	DC block Bias on output port
A-GABL1-3337	In-line	Flat	15	DC block Bias on output port
A-GABL1-3338	In-line	Flat	20	DC block Bias on output port
A-GABL1-3339	In-line	Flat	25	DC block Bias on output port
A-GABL1-3340	In-line	Flat	30	DC block Bias on output port
A-GABL1-3341	In-line	Flat	10	DC pass and 10MHz Pass on all ports
A-GABL1-3342	In-line	Flat	15	DC pass and 10MHz Pass on all ports
A-GABL1-3343	In-line	Flat	20	DC pass and 10MHz Pass on all ports
A-GABL1-3344	In-line	Flat	25	DC pass and 10MHz Pass on all ports
A-GABL1-3345	In-line	Flat	30	DC pass and 10MHz Pass on all ports
A-GABL1-3347	In-line	Flat	10	DC block Bias on input port
A-GABL1-3348	In-line	Flat	15	DC block Bias on input port
A-GABL1-3349	In-line	Flat	20	DC block Bias on input port
A-GABL1-3350	In-line	Flat	25	DC block Bias on input port
A-GABL1-3351	In-line	Flat	30	DC block Bias on input port
A-GABL1-3352	In-line	Flat	10	DC and 10MHz block Bias on output port
A-GABL1-3353	In-line	Flat	15	DC and 10MHz block Bias on output port
A-GABL1-3354	In-line	Flat	20	DC and 10MHz block Bias on output port
A-GABL1-3355	In-line	Flat	25	DC and 10MHz block Bias on output port
A-GABL1-3356	In-line	Flat	30	DC and 10MHz block Bias on output port
A-GABL1-3357	In-line	Flat	10	DC and 10MHz block Bias on output port
A-GABL1-3358	In-line	Flat	15	DC and 10MHz block Bias on output port
A-GABL1-3359	In-line	Flat	20	DC and 10MHz block Bias on output port
A-GABL1-3360	In-line	Flat	25	DC and 10MHz block Bias on output port
A-GABL1-3361	In-line	Flat	30	DC and 10MHz block Bias on output port

* Custom designs available on request

ETL SYSTEMS LIMITED
Coldwell Radio
Station
Madley
Hereford

England HR2 9NE
TELEPHONE
+44 (0)1981 259020

EMAIL
info@etlsystems.com
FACSIMILE
+44 (0)1981 259021



V 1.1 E&OE