

L-band Amplifiers



The 3130-3134 series of L-band Amplifiers offer flat frequency versus gain characteristics over 850 to 2150MHz with DC pass on both ports and gain options of 10, 15, 20, 25 and 30dB. Requires 8-24V DC from the inline RF cable.

These components are available with the following RF connector options: 50 Ω SMA, N-type, BNC and 75 Ω BNC or F-type.

Vector diagram and physical dimensions

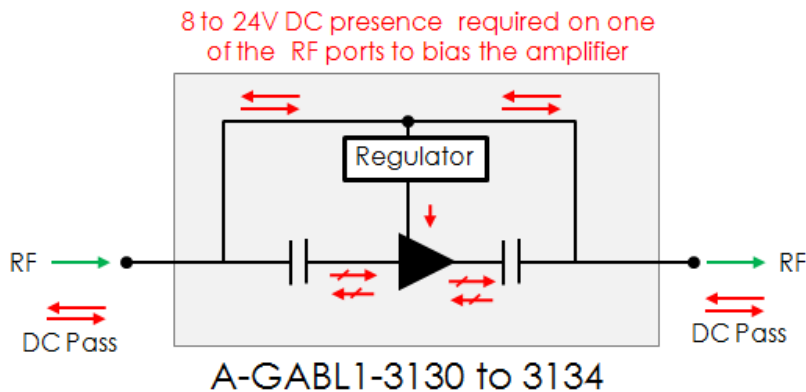

Maximum acceptable operating parameters for reliable and safe operation

Parameter	Value	Comment
Input RF power	+16 dBm (40mW)	Max total RF power
Max voltage: RF ports	24V	DC pass on all RF ports
Max voltage: DC bias input	24V	
Max DC current	500mA	This is max DC pass between the RF ports.
Operating temperature	0 to 55°C	Indoor use only
Storage Temperature	-20°C to +75°C	
Humidity	85%	Non-condensing
Altitude	10,000 feet	Above Mean Sea Level

! Operation beyond these limits may cause instantaneous and permanent damage.



A-GABL1-3130 - 3134

L-band Gain Block Amplifiers



Typical performance over L-band operation, 850MHz to 2150MHz

Model Number	Gain (dB)	Gain vs. Frequency variation (dB)		Input return loss (dB)		Output return loss (dB)		1dB GCP (dBm)		IP3 (dBm)	NF (dB)
	Typical	Typ.	Max.	Typ.	Max.	Typ.	Max.	Typ.	Max.	Typical	Typical

Model 3130

A-GABL1-3130-S5S5	20±1.5	±0.5	±0.7	15	10	20	14	12	8	22	9
A-GABL1-3130-N5N5	20±1.5	±0.5	±0.7	15	10	20	14	12	8	22	9
A-GABL1-3130-B5B5	20±1.5	±0.5	±0.8	14	10	20	14	12	8	22	9
A-GABL1-3130-B7B7	20±1.5	±0.7	±1.0	12	8	14	10	12	8	22	9
A-GABL1-3130-F7F7	20±1.5	±1.0	±1.25	12	8	14	10	12	8	22	9

Model 3131

A-GABL1-3131-S5S5	10±1.0	±0.3	±0.7	20	14	22	18	15	10	25	10
A-GABL1-3131-N5N5	10±1.5	±0.3	±0.7	20	14	22	18	15	10	25	10
A-GABL1-3131-B5B5	10±1.5	±0.4	±0.8	19	14	22	18	15	10	25	10
A-GABL1-3131-B7B7	10±1.5	±0.6	±0.8	17	12	18	14	15	10	25	10
A-GABL1-3131-F7F7	10±1.5	±0.8	±1.0	17	12	16	12	15	10	25	10

Model 3132

A-GABL1-3132-S5S5	15±1.5	±0.5	±0.7	20	14	22	18	15	10	25	10
A-GABL1-3132-N5N5	15±1.5	±0.5	±0.7	20	14	22	18	15	10	25	10
A-GABL1-3132-B5B5	15±1.5	±0.5	±0.8	19	14	22	18	15	10	25	10
A-GABL1-3132-B7B7	15±1.5	±0.7	±1.0	17	12	18	14	15	10	25	10
A-GABL1-3132-F7F7	15±1.5	±1.0	±1.25	17	12	16	12	15	10	25	10



ETL Systems Ltd, Coldwell Radio Station, Madley, Hereford, HR2 9NE, England

ETL Systems design, develop and manufacture specialist equipment for satellite ground stations. For a full description of the ETL product range, please see our website at www.etlsystems.com. This product range provides the basis for meeting your specific demands.

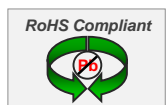

Tel +44 (0)1981 259020
 Fax +44 (0)1981 259021
info@etlsystems.com

A-GABL1-3130 - 3134

L-band Gain Block Amplifiers



Typical performance over L-band operation, 850MHz to 2150MHz

Model Number	Gain (dB)	Gain vs. Frequency variation (dB)		Input return loss (dB)		Output return loss (dB)		1dB GCP (dBm)		IP3 (dBm)	NF (dB)
	Typical	Typ.	Max.	Typ.	Max.	Typ.	Max.	Typ.	Max.	Typical	Typical

Model 3133

A-GABL1-3133-S5S5	25±1.5	±0.7	±0.9	15	10	20	14	15	10	25	8
A-GABL1-3133-N5N5	25±1.5	±0.7	±0.7	15	10	20	14	15	10	25	8
A-GABL1-3133-B5B5	25±1.5	±0.8	±0.8	14	10	20	14	15	10	25	8
A-GABL1-3133-B7B7	25±1.5	±1.0	±1.0	12	8	14	10	15	10	25	8
A-GABL1-3133-F7F7	25±1.5	±1.2	±1.25	12	8	14	10	15	10	25	8

Model 3134

A-GABL1-3134-S5S5	30±2	±0.7	±0.9	12	10	20	14	15	10	25	8
A-GABL1-3134-N5N5	30±2	±0.7	±0.7	12	10	20	14	15	10	25	8
A-GABL1-3134-B5B5	30±2	±0.8	±0.8	11	10	20	14	15	10	25	8
A-GABL1-3134-B7B7	30±2	±1.0	±1.0	12	8	14	10	15	10	25	8
A-GABL1-3134-F7F7	30±2.5	±1.2	±1.25	12	8	14	10	15	10	25	8



ETL Systems Ltd, Coldwell Radio Station, Madley, Hereford, HR2 9NE, England

ETL Systems design, develop and manufacture specialist equipment for satellite ground stations. For a full description of the ETL product range, please see our website at www.etlsystems.com. This product range provides the basis for meeting your specific demands.

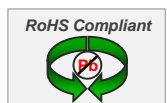

Tel +44 (0)1981 259020
 Fax +44 (0)1981 259021
info@etlsystems.com

A-GABL1-3130 - 3134

L-band Gain Block Amplifiers



Physical dimensions

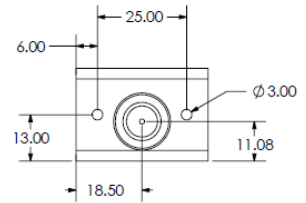
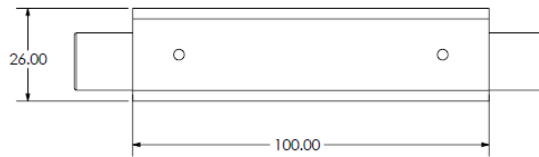
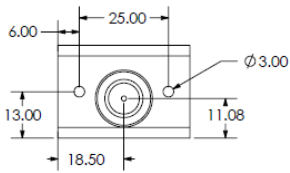
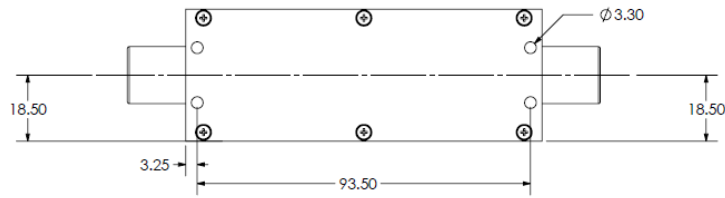

Alternative L-band Gain Block Amplifiers

Model Numbers	Bias Option*	Freq vs. Gain	Gain Options (dB)	Other features
3110-3114	External	Flat	10 to 30	DC block on all ports
3130-3134	In-line	Flat	10 to 30	DC pass on all ports
3135	In-line	Flat	25dB	DC block on input port only
3136	In-line	Flat	Unity	10MHz and DC pass on all ports
3204	External	Flat	Unity	10MHz pass and DC block on both ports
3140-3143	External	Flat	10 to 25	10MHz pass and DC block on both ports
3218, 3219 & 3210	External	Flat	20, 25 & 30dB options	10MHz and DC pass on all ports
3145-3147	External	3dB +ve slope	10, 15, 20	DC block on both ports
3207-3209 & 3139	In-line	Flat	10, 15, 20, 28	10MHz and DC pass on all ports
3148-3150	External	6dB +ve slope	10, 15, 20	DC block on both ports
3151-3153	In-line	3dB +ve slope	10 15, 20	DC block on input port only
3154-3156	In-line	6dB +ve slope	10, 15, 20	DC block on input port only
3213, 3214 & 3222	External	Flat	10, 20, 30	LNB injection onto input port, DC block on output port
3223	External	Flat	25	DC block on all ports, extended frequency 850 to 2500 MHz

* In Line bias: This option requires DC on an RF port



ETL Systems Ltd, Coldwell Radio Station, Madley, Hereford, HR2 9NE, England

ETL Systems design, develop and manufacture specialist equipment for satellite ground stations. For a full description of the ETL product range, please see our website at www.etlsystems.com. This product range provides the basis for meeting your specific demands.

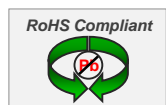

Tel +44 (0)1981 259020
 Fax +44 (0)1981 259021
info@etlsystems.com