

SpacePath StellarMini™ 180W Ku-Band Antenna Mount TWTA

The STA3318 range of Ku-Band TWT amplifiers from SpacePath Communications provide over 150W of output power in a compact, lightweight, rugged, weatherproof, antenna mount enclosure. The advanced packaging and cooling techniques enable the unit to operate in extreme environmental conditions from direct rain to direct sunlight. The amplifiers can be deployed globally, are easy to integrate, user-friendly, and incorporate a comprehensive remote control facility as standard, including SNMP V3 and a feature-rich web user interface, alongside RS485, and RS232.

The HPA incorporates a high efficiency dual collector TWT powered by a state-of-the-art power supply that further advances the company's reputation for robust, reliable product. In addition the circulator, receive band filter and harmonic filter are included as standard, eliminating the need for additional external components. With the internal Lineariser fitted, it offers twice the useable output power.

The STA3318 is available with a wide range of options and accessories, backed by round-the-clock, worldwide technical support.

Features

- Lightweight and compact
- High operating temperature
- Circulator, receive band filter and harmonic filter included as standard
- Weatherproof antenna mount construction allows exposed mounting
- Redundant control - contains control and drive circuits for 1:1 redundancy
- Stand-alone setting - automatically sequences to transmit mode
- Wide range of accessories including: controllers, waveguide networks, cable assemblies, ducting adaptor and cowl
- Round-the-clock hotline support



Options

- Gain control
- L-band block upconverter
- Break-out link for upconverter
- Internal Lineariser

Block Diagram

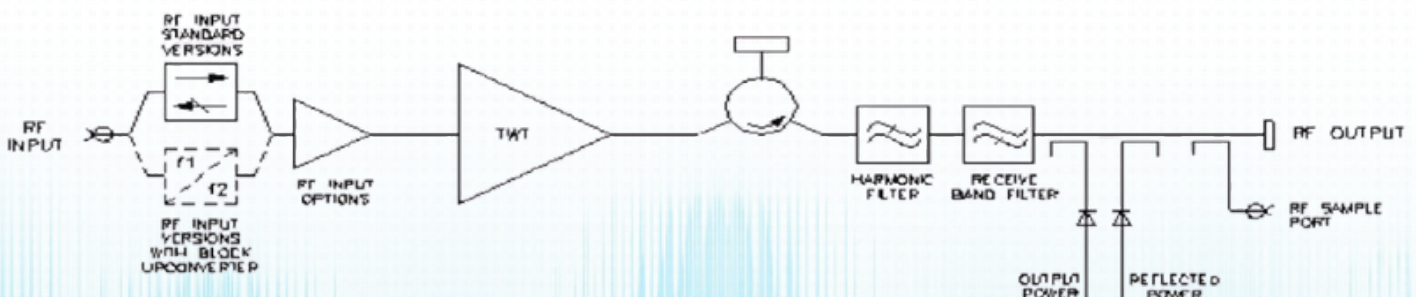

RF Performance (Without Upconverter)		
Frequency range	Standard - KU1: 13.75 – 14.5 GHz Extended - KU2: 12.75 – 14.5 GHz Extended - KU3: 13.75 – 14.8 GHz	
Output Power	TWT output flange	175 W min
	HPA rated output	150 W min
Gain at rated power (A, D option)	61 dB min	
Gain at SSG P _{1dB} -10dB (A, D option)	66 dB min	
Attenuation range (D option)	25 dB min	
Gain Variation over any 80 MHz band	1.0 dB max	
Slope, ΔG_{SLOPE}	0.1 dB/MHz max	
Gain Stability vs. Time	0.5 dB max / 24hrs @ constant drive and temperature	
Gain Stability vs. Temperature	2.0 dB max / 24hrs @ constant drive and frequency	
Adjustment range, G_{ADJ}	30.0 dB typical	
Adjustment step size	0.1 dB	
AM/PM	$\leq 2.5^\circ/\text{dB}$ @ Prated-6 dB	
Inter-modulations (IMD) 2 equal carriers 10MHz apart	≤ -18 dBc @ Prated-4 dB ¹ ≤ -28 dBc @ Prated-4 dB ²	
Noise power	Transmit band	≤ -70 dBW/4 kHz
	Receive band	≤ -150 dBW/4 kHz (10.95 - 12.75 GHz - standard)
Spurious @ $P_O \leq MLP$	≤ -60 dBc	
Residual AM	≤ -50 dBc, $f < 10\text{kHz}$ $\leq -20(1.5+\text{LOG}(\text{frequency KHz}))\text{dBc}$, $f = 10\text{kHz}$ to 500kHz ≤ -85 dBc $>500\text{kHz}$	
Phase Noise	10dB below IESS requirement ≤ -50 dBc max, AC fundamental ≤ -47 dBc max, Sum of all spurs	
Group Delay	Linear	0.01 nsec/MHz, max
	Parabolic	0.005 nsec/MHz ² , max
	Ripple	1.0 nsec/Peak-Peak, max
Input VSWR (Return Loss)	$\leq 1.3:1$ (17.7 dB)	
Output VSWR (Return Loss)	$\leq 1.3:1$ (17.7 dB)	
Load VSWR (no damage)	$\leq 2.0:1$ (9.5 dB)	
Harmonic 2 nd & 3 rd	-60 dBc max	

1) No Linearizer 2) With Linearizer

Electrical	
Prime power	single phase, line-neutral or line-line
Voltage	99-265 V
Frequency	47-63 Hz
Power requirement	850 VA max
Power factor	0.95 min

Physical	
Dimensions (request outline)	58.8 cm deep x 25.4 cm width x 27.1 cm height
Weight	9KG (19.8 lb) typ
Cooling	Integral forced-air
RF Input	N-type female
RF Output	PBR120 with 6-32 UNC 2B threaded holes
RF Sample port	N-type female
AC Input	Amphenol T3110-000
Control interface	62GB-12E-18-32-PN

Note: Mating connectors for the mains supply and control interface are supplied

Environmental	
Operating temperature	-40°C to +55°C
Storage temperature	-40°C to +85°C
Derating	2°C/300m above sea level (3.5°F/1000ft)
Relative humidity	100% condensing
Altitude	operating: 4.5 km (15,000 ft) max non-operating: 12 km (40,000 ft) max
Vibration/shock	BS EN 60721-3-2 Level 2M3
Solar Gain	1120 W/m ²

The amplifier complies with EU Directive 2002/95/EC, the RoHS dB max Directive, restricting the use of hazardous substances in electronic equipment.

The amplifier falls within the scope of EU Directive 2002/96/EC, the WEEE Directive, governing disposal at end of life. Users should contact ETL Systems or their distributors for disposal information.

Note 1: The specification is subject to regular reviews and will be updated from time to time as part of our continuing product development and improved spec accuracy.

Note 2: Operation beyond the quoted limits stated above may cause instantaneous and permanent damage.

Controls		
Remote Control	Off Standby Transmit RF inhibit	High Power Alarm Set Low Power Alarm Set Auto Redundancy Control RF Switch Control Gain Control (when fitted)
Remote Status/Monitor	Off Warm-up Standby Transmit Fault Summary Reflected Power External interlock TWT too hot Mean Helix Current Peak Helix Current High Power Alarm Low Power Alarm	Output Power Monitor Reflected Power Monitor Helix Current Monitor Helix Voltage Collector Voltages Heater Voltage Heater Current Elapsed Hours
Interfaces	Serial: RS-422/485 / Ethernet User*: Dry Relay Contact	
Other features	Auxiliary Output Voltage Redundant system & waveguide switch drive 'Stand Alone' setting for automatic power up	

*Note: User Interface provides: Transmit On/Off control, Status Outputs, Summary and Redundancy Fault Outputs.

Options

Extensive options are offered with the STA3318 and include: integral pre-amplifiers, gain control and block upconverters. The options are defined by adding to the base number as shown below:

Input Options

The STA3318 can be offered with an L-Band Block Upconverter. Specify:

N - Standard RF

U-L -Ku Band Upconverter (see page 4)

Note: the upconverter requires the inclusion of either the 'D' or 'Z' options. (Consult SpacePath Communications for availability).

Break-Out Links

Available only with the upconverter option, this enables bypassing of the upconverter and can be used for monitoring, set-up, redundant switching etc. Specify 'S' for Break-Out Links (leave blank if not required).

Accessories

The STA3318 is supplied with an operation manual, prime power connector mating part, interface connector mating part. Additional accessories include:

- N6081x-01 Series Control Unit

Provides basic control of single HPA.

- SPC1U01 1:1 Control Unit

Provides control of 2 HPAs in 1:1 switch configuration. (The waveguide switch network can also be supplied).

- Cable Assemblies

For connecting STA3318 to controllers and waveguide switches.

- DPP710351BA Transition

Provides an interface for ducting and cowl fitment.

- DPP710353BA Cowl

For more information on accessories, contact ETL Systems.

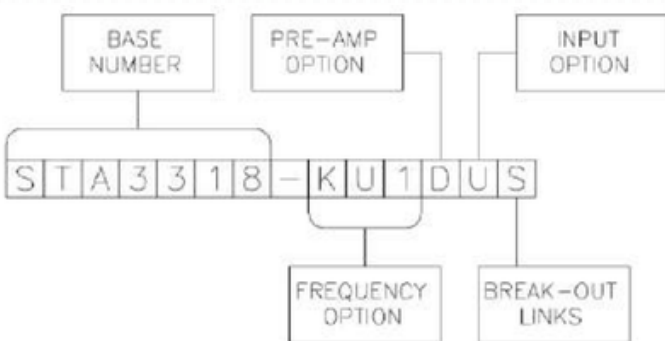

Frequency Options

The STA3318 is offered in a number of frequency bands:

KU1 - 13.75 - 14.50 GHz

KU2 - 12.75 - 14.50 GHz

KU2 - 13.75 - 14.80 GHz

Pre-Amp Option

The pre-amp option can be selected from any of the following:

A - Integral solid-state amplifier (typical SSG 78 dB).

D - As option 'A' but includes an attenuator to provide

25 dB (min.) of gain control.

RF Performance with Integral Block Upconverter		
Frequency range	Option KU1: 13.75 – 14.5 GHz Option KU2: 12.75 – 14.5 GHz	
L-band input	Option KU1: 950 – 1700 Mhz Option KU3: 950 – 1450 Mhz Level: 10 dBm max	
LO frequency	Option KU1: 12.8 GHz Option KU3: 13.05 GHz	
External reference	Frequency: 10 Mhz Level: -3 to +7 dBm Impedance: 50 Ω	
Output Power	TWT output flange	175 W min
	HPA rated output	150 W min
Gain at rated power (A, D option)	61 dB min	
Gain at SSG P _{1dB} -10dB (A, D option)	66 dB min	
Attenuation range (D option)	25 dB min	
Gain Variation	4.0 dB max over full band 1.5 dB max over any 80 MHz band	
Slope, ΔG_{SLOPE}	0.08 dB/MHz max	
Gain Stability vs. Time	0.5 dB max / 24hrs @ constant drive and temperature	
Gain Stability vs. Temperature	2.0 dB max / 24hrs @ constant drive and frequency	
AM/PM	$\leq 2.5^\circ/\text{dB}$ @ Prated-6 dB	
Inter-modulations (IMD) 2 equal carriers 10MHz apart	options A, D: -23 dBc max	
Noise power	Transmit band	≤ -70 dBW/4 kHz
	Receive band	≤ -150 dBW/4 kHz (10.95 - 12.75 GHz - standard)
Spurious @ P ₀ \leq MLP	≤ -60 dBc	
Residual AM > 100 kHz from carrier	-60 dBc max	
Phase Noise	meets IESS requirement ≤ -50 dBc max, AC fundamental ≤ -47 dBc max, Sum of all spurs	
Group Delay	Linear	0.01 nsec/MHz, max
	Parabolic	0.005 nsec/MHz ² , max
	Ripple	1.0 nsec/Peak-Peak, max
Input VSWR (non-operating)	1.6:1 max	
Output VSWR (non-operating)	1.3:1 max	
Load VSWR (no damage)	2.0:1 max	
Harmonic 2 nd & 3 rd	-60 dBc max	

*Note: For S-Link version, gain is decreased by 4 dB.

HEALTH AND SAFETY HAZARDS

Stellar satellite amplifiers are safe to handle and operate provided that the relevant precautions are observed. ETL Systems does not accept responsibility for damage or injury resulting from the use of electronic devices it produces.

High Voltage

Dangerous voltages are present within the TWT amplifier when operating normally. However, the equipment is designed so that personnel cannot come into contact with high voltage circuits unless covers are removed.

RF Radiation

All RF connectors must be correctly fitted before operation.

Beryllia

The TWT in the amplifier contains Beryllium Oxide ceramic parts. These are not accessible unless the TWT casing is damaged. Consult ETL Systems regarding the disposal of damaged or life expired tubes.

Features

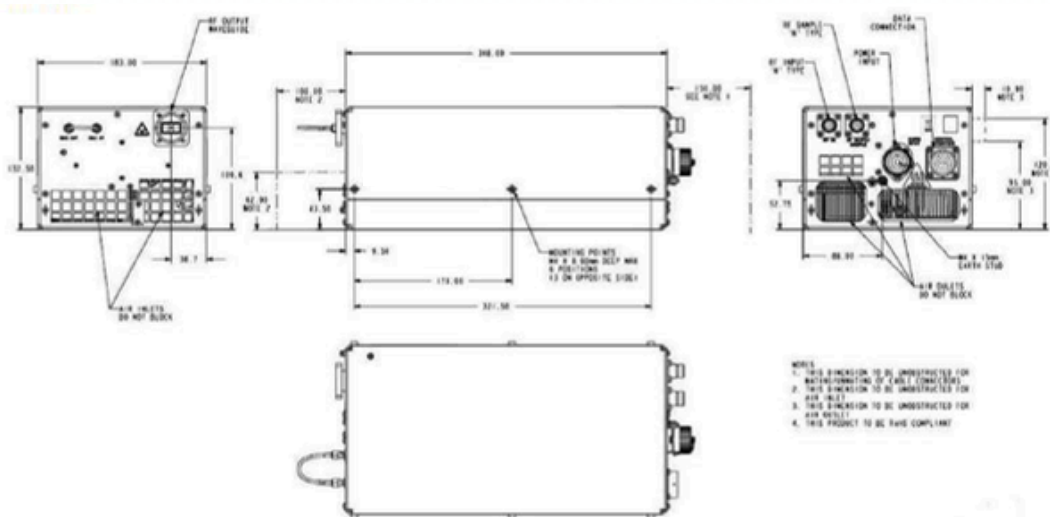

Packed Gross Weight & Dimension
9.80kg 57x33x29cm