

Fanless 8-12-16W Ku-Band BUC / SSPA

Powered by GaN technology the fanless series are revolutionary in size, weight and power density. The fanless version offers superior performance, thermal efficiency and high reliability in an extremely compact package. Weighing at only 2.75kgs, our fanless GaN BUC is exceptionally powerful for its size: up to 16W Psat. Built in Isolated DC power supply provides the customer with the feed-from-a battery solution. Fanless BUC features best in class RF characteristics, built in output circulator, extensive monitor and control capabilities enabled via Ethernet, Serial and/or Analog Interfaces.

The BUC's remarkably small size and low power consumption results in better heat extraction that allows its operation at passive (convection) cooling, which eliminates fan - least reliable and most maintenance-requiring component of any BUC. Its small size and weight allows direct feed horn mounting, which makes it a most economical solution for fixed and mobile VSAT applications

Features

- Up to 16W Output Power in this super-compact light weight package 14.5 x 13.5 x 10cms only!
- High thermal efficiency resulting in fanless package
- Only 130W Power consumption at 16W output
- RF Monitor Port Optional
- Superior RF performance:
 - o High Linearity
 - o Spurious below-60dBc
 - o Wide dynamic range of Gain Control
 - Output power measurement
 - Built In output isolator provides full output VSWR Protection
 - Configuration packet protocol RS-485 - User friendly HTTP based GUI and SNMP
 - VDC isolated power supply
 - Field upgradable software
 - Status LED



Outline

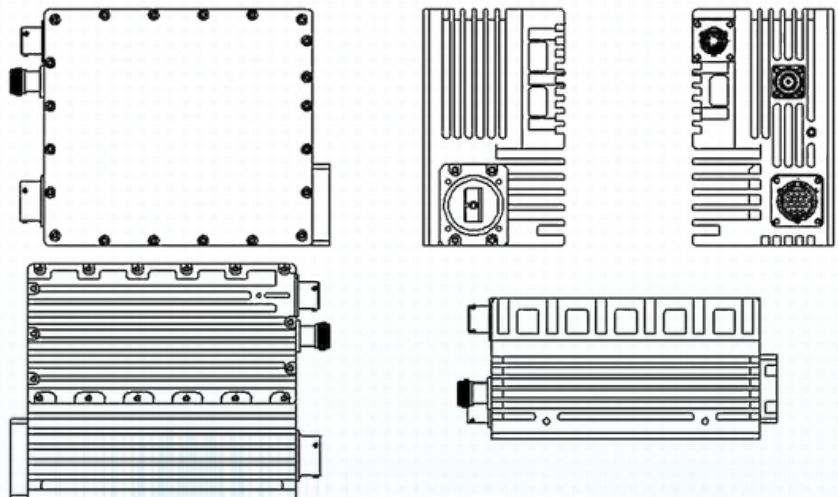



RF Parameters				
		8W	12W	16W
RF Frequency Range		13.75-14.50GHz		
IF Frequency Range		950-1700MHz		
LO Frequency		12.8GHz		
Rated Power		39dBm nom	41dBm nom	42dBm nom
Plinear		36dBm nom	38dBm nom	39dBm nom
Gain		69dB min, 72dB typ		
Gain Flatness		+/-1dB typ +/-1.5dB max over full band; +/-0.5dB max over any 40MHz		
Gain Stability		+/-1.5dB over full temperature range		
Gain Control		20dB min dynamic range with 0.1dB step		
External Reference Frequency		10MHz multiplexed with IF In		
External Reference Required Phase Noise		-130dBc/Hz @100Hz -140dBc/Hz @ 1kHz -150dBc/Hz @ 10kHz -155dBc/Hz @ 100kHz		
Up-Converter Phase Noise		-68dBc/Hz @ 100Hz -80dBc/Hz @ 1kHz -90dBc/Hz @ 10kHz -95dBc/Hz @ 100kHz -115dBc/Hz @ 1MHz		
Linearity:	2 tone IMD	-24dBc at P linear		
	Spectral Re-growth	-30dBc for QPSK at 1.5 x symbol rate at P linear		
Noise Power Density:	Transmit Band	-85dBm/Hz max		
	Receive Band	-140dBm/Hz max		
Output Spurious:	Non-signal related	-65dBc		
	Signal related	-60dBc		
RF Monitor (Optional)		-40dBc nom		
Power & Mechanical				
48V DC Voltage Range		36-72VDC Isolated / 18-36VDC Isolated (optional)		
Power Consumption - DC power in/AC power in		75W/90W	85W/110W	90W/120W
Size		14.5x13.5x10cms		
Weight		2.75KG		
Cooling		Forced Air		
Operating Temperature / Relative Humidity		-40°C to +55°C / Up to 100% condensing		
Interfaces				
IF Input Connector		N-type Female		
RF Output Connector		WR75 grooved		
RF Monitor (optional)		SMA female		
AC Power In		MS3112E10-8P		
RS485 - Ethernet - SNMPv3		MS3112E14-19S		

Note 1: The specification is subject to regular reviews and will be updated from time to time as part of our continuing product development and improved spec accuracy.

Note 2: Operation beyond the quoted limits stated above may cause instantaneous and permanent damage.