

# 1:1 & 1:2 Uplink C / X / Ku-Band SSPA/BUC Redundant System

The IRT IRK® (Intelligent Redundant Kit) Series C / X / Ku-Bands 1:1 and 1:2 redundancy system is light weight and super-compact due to revolutionary small size IRT BUCs / SSPAs equipped with intelligent built-in redundancy controller; that's why the IRK® system does not require an external redundancy controller for regular 1:1 configuration; means there is no single point failure in the redundant system and its reliability is much higher. IRK® Series also offers special redundancy configurations with additional switches for Air/Load switching and for Vertical/Horizontal polarizations switching.

Special face-to-face mechanical configuration makes it ideal for SNG application. 1:2 Redundancy system has an option of universal mechanical solution – any IRT BUC can be used in such system, which makes easy any system upgrade or replacement. IRK® Series features extensive monitor & control via serial ports EIA232/EIA485 and Ethernet. The state-of-the-art web browser provides the operator with comprehensive system management tool.

## Features

- Eliminates External Redundancy Controller as a Single Point of Failure for the regular 1:1 system
- Easy BUC/PA unit's replacement without interruption of traffic
- Remote Control over RS-232, RS-485 and Ethernet.
- Built-in SNMPv3 and Web Server
- Auto, Remote, Manual Override Operational Modes
- Manual Switch-Over Button
- BUC A/B Gain Equalization Feature
- Universal 1:2 redundancy configuration fits any IRT BUC
- Super-compact mechanical solution for mobile applications

## Options & Accessories

- Power Distribution Junction Box
- Indoor 1RU Remote Control Panel Optional
- Additional Air/Load Switch Optional
- Horizontal/Vertical polarization switching Optional
- Mechanical customization for compact mobile antennas



RF Parameters	
RF Frequency, GHz	5.85 - 6.425GHz / 7.9 - 8.4GHz / 13.75 - 14.5GHz (Other frequencies available, please enquire)
IF Frequency Range, MHz	950 - 1525MHz / 950 - 1700MHz
Return Loss at IF In Port	-14dB maximum
Return Loss at RF Out Port	-16dB maximum
Output Power	Up to 1000W at PSAT
Input IF port Impedance	50 Ohm

Power	
AC Option	90-265VAC(up to 200W); 190-265VAC (250W+) 50-60Hz to each BUC/SSPA
DC Option (16-100W only)	36-55 VDC Isolated to each BUC/SSPA

Interfaces	
IF IN (L-Band and 10MHz)	N-type female
RF Out	CPR137/WR75 Grooved
User Interface	MS3112E14-19S

Monitor & Control Features	
Controls	Indicators
Online/Standby Toggle (Via Serial, Ethernet) Mute Control (Via Serial, Ethernet) Gain Control (Via Serial, Ethernet) Gain equalization offset (Via Serial, Ethernet) Hot standby/Cold Standby (Via Serial, Ethernet) Air/Load Toggle (optional) (Via Serial, Ethernet) Air/Load Toggle (optional) (Via Serial, Ethernet)	Active/Stand by status (Via Serial, Ethernet) Mute Status (Via Serial, Ethernet) Switch Position (Via Serial, Ethernet, LED) BUC A/B full telemetry (Via Serial, Ethernet) Event Log (Via Serial, Ethernet) Alarm A/B details (Via Serial, Ethernet)

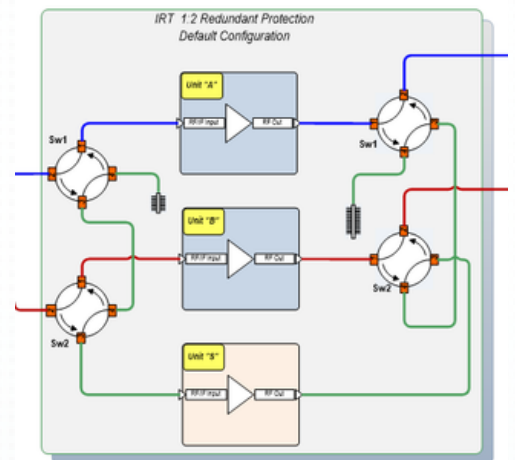
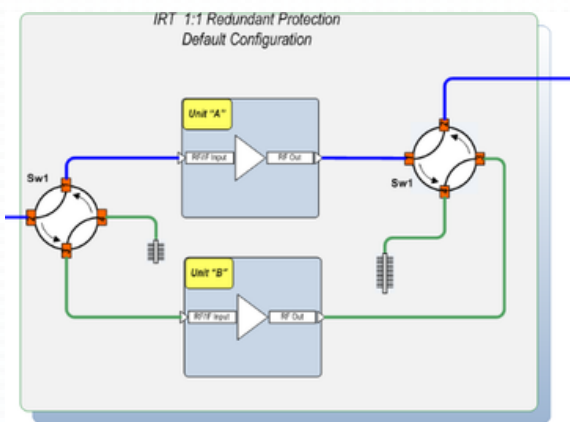

Note 1: The specification is subject to regular reviews and will be updated from time to time as part of our continuing product development and improved spec accuracy.  
 Note 2: Operation beyond the quoted limits stated above may cause instantaneous and permanent damage.