

L-band Passive Equalisers

75Ω impedance range



The 4531-4540 series are 75 ohm passive L-band positive slope equalisers available in 1dB slope increments over 1 to 10dB range. These are reciprocal devices with DC and 10MHz pass between the two ports. These components are available with the following RF connector options: 75 Ω SMA, N-type and BNC.

Physical dimensions and appearance

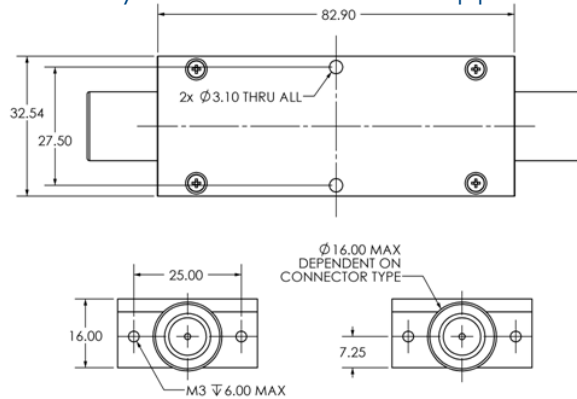

Vector Diagram

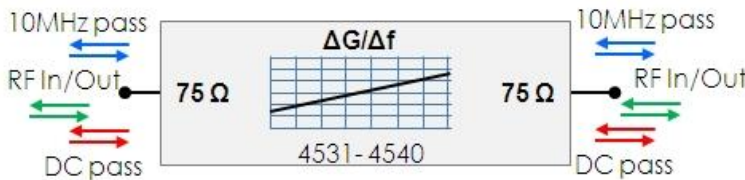

Maximum acceptable operating parameters for reliable and safe operation

Parameter	Value	Comment
Input RF power	+37 dBm (5W)	Max total RF power
DC Rating	28V / 3A	
Operating temperature	0 to 65 C	Indoor use only
Storage Temperature	-20 C to +75 C	
Humidity	90%	Non-condensing

! Operation beyond these limits may cause instantaneous and permanent damage.



EQU1P-4531 to 4540

L-band Passive Equaliser



Typical performance - L-band passive equalisers

Model Number	Positive slope (dB)	Slope vs. Frequency variation (dB)	Insertion Loss* (dB)		Return Loss (dB)	
			Typ.	Max	Typ.	Min

EQU1P-4531

EQU1P-4531-B7B7	1	±0.3	2.0	3.5	12	8
EQU1P-4531-F7F7	1	±0.3	2.0	3.5	10	6

EQU1P-4532

EQU1P-4532-B7B7	2	±0.5	2.5	3.5	12	8
EQU1P-4532-F7F7	2	±0.5	2.5	3.5	10	6

EQU1P-4533

EQU1P-4533-B7B7	3	±0.8	2.5	3.5	14	8
EQU1P-4533-F7F7	3	±0.8	2.5	3.5	12	8

EQU1P-4534

EQU1P-4534-B7B7	4	±1.0	3.0	5.0	14	8
EQU1P-4534-F7F7	4	±1.0	3.0	5.0	12	8

EQU1P-4535

EQU1P-4535-B7B7	5	±1.2	4.5	6.0	14	8
EQU1P-4535-F7F7	5	±1.2	4.5	6.0	12	8

EQU1P-4536

EQU1P-4536-B7B7	6	±1.5	5.5	7.5	14	8
EQU1P-4536-F7F7	6	±1.5	5.5	7.5	12	8

* Mid-band insertion loss



ETL Systems Ltd, Coldwell Radio Station, Madley, Hereford, HR2 9NE, England

ETL Systems design, develop and manufacture specialist equipment for satellite ground stations. For a full description of the ETL product range, please see our website at www.etlsystems.com. This product range provides the basis for meeting your specific demands.

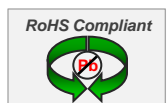

Tel +44 (0)1981 259020
Fax +44 (0)1981 259021
info@etlsystems.com

EQUL1P-4531 to 4540

L-band Passive Equaliser



Typical performance - L-band passive equalisers

Model Number	Positive slope (dB)	Slope vs. Frequency variation (dB)	Insertion Loss* (dB)		Return Loss (dB)	
			Typ.	Max	Typ.	Min

EQUL1P-4537

EQUL1P-4537-B7B7	7	±1.5	5.5	8.0	12	8
EQUL1P-4537-F7F7	7	±1.5	5.5	8.0	10	8

EQUL1P-4538

EQUL1P-4538-B7B7	8	±1.7	6.0	8.5	12	8
EQUL1P-4538-F7F7	8	±1.7	6.0	8.5	10	8

EQUL1P-4539

EQUL1P-4539-B7B7	9	±2.0	6.5	9.0	12	8
EQUL1P-4539-F7F7	9	±2.0	6.5	9.0	10	8

EQUL1P-4540

EQUL1P-4540-B7B7	10	±2.0	6.5	9.0	10	8
EQUL1P-4540-F7F7	10	±2.0	6.5	9.0	8	8

* Mid-band insertion loss

ETL's L-band passive frequency equalisers range

Model Number	Positive Slope Range	RF Connector Impedance	Other features
EQUL1P-4501 to 4510	1 to 10dB	50Ω	DC block
EQUL1P-4511 to 4520	1 to 10dB	75Ω	DC block
EQUL1P-4521 to 4530	1 to 10dB	50Ω	DC and 10MHz Pass
EQUL1P-4531 to 4540	1 to 10dB	75Ω	DC and 10MHz Pass

Please note: custom products are available. Please contact us with your enquiry



ETL Systems Ltd, Coldwell Radio Station, Madley, Hereford, HR2 9NE, England

ETL Systems design, develop and manufacture specialist equipment for satellite ground stations. For a full description of the ETL product range, please see our website at www.etlsystems.com. This product range provides the basis for meeting your specific demands.

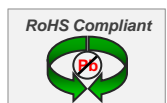

Tel +44 (0)1981 259020
 Fax +44 (0)1981 259021
info@etlsystems.com